

Astronomical Filters Part 4

Special Filters

By Jim Thompson

My discussion of Planetary and Deep-Sky filters in the preceding three articles of this series may have given you the impression that is all there is to know about astronomical filters. Well, fortunately (or unfortunately!) that is not the case. The development of interference-type coatings and the ability to customize them to achieve any spectral response desired have resulted in a large number of other miscellaneous filters that I simply refer to as “special.” Astronomers are interested in a broad range of celestial targets, and as a result interference filters have been developed to do more than just reduce light pollution.

Our Four Classes of “Special” Filters

My personal experience is with only a small number of these special filters, but I do my best in this article to describe the different special filters that are available and give some guidance on how to choose the right one for you. Special filters are quite a mixed bag of types and applications. To try to sort things out I have divided them into four categories: (1) Special, Planetary, (2) Special, Neodymium, (3) Special, Correction and (4) Special, Solar (a) White Light and (b) Narrow Band.

The first two categories are touched on briefly in the previous articles, but as of yet I have not discussed the later two. I have



Image 1 – A Motley Crew of Special Filters. Interference coatings have been used to make filters for a wide variety of applications, not just light-pollution rejection.

further subdivided Solar filters into those working with all or most of the colour spectrum (white), and those dedicated to an extremely narrow wave band within the visible spectrum.

Not included in my four categories above are filters that manage light outside the visible spectrum, ultraviolet (below violet) and infrared (above red). There is a family of filters that block UV and IR, and another family of filters that pass UV or IR but block the visible spectrum. These filters are all intended for photography since the human eye is not sensitive to these wavelengths of light.

UV pass filters are used for planetary photography, revealing features not discernable in the visible spectrum. IR pass filters are similar, used for planetary photography since the perturbations of the

image due to the atmosphere are less pronounced in the infrared band. UV/IR blocking filters are used to pass only the visible spectrum, resulting in sharper and better focused images. This is so because most lenses and telescopes are designed to properly focus only visible light, not UV and IR as well. I will discuss using UV/IR blocking and IR pass filters more in a future article about using filters in video astronomy.

Special Planetary Filters

Let's begin with the special filters I know the most about, those designed for planetary work. Planet observing is notorious for poorly contrasted views. There is so much sun light reflecting off the planets we observe, surface details often appear washed out. Historically, astronomers have used colour filters in an attempt to darken cer-

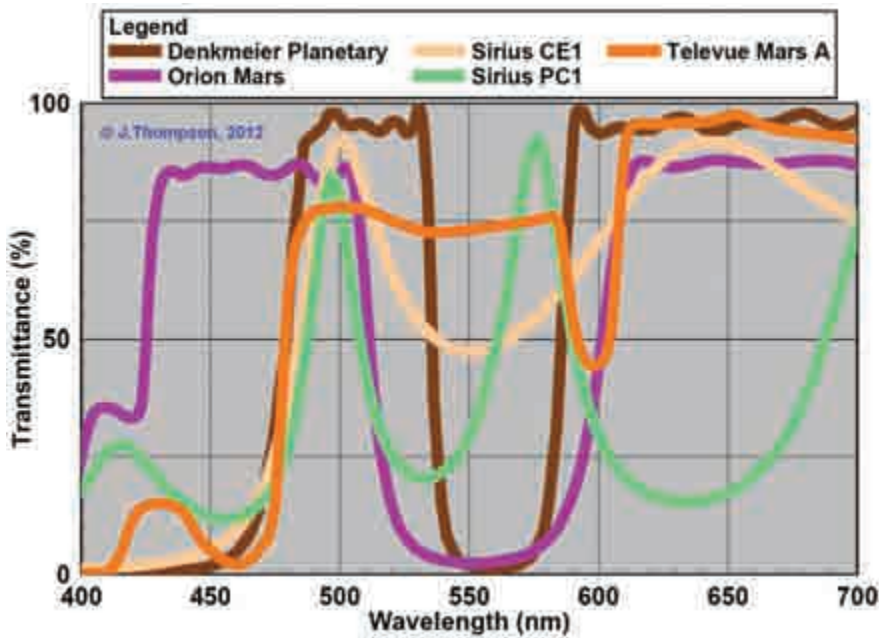

Image 2 – Spectral Response of Special Planetary Filters. Interference coating technology has been used to make filters that improve the contrast of planetary surface features.

tain surface features relative to others in order to make them more visible. By applying interference coating technology to this problem, unique filters that accentuate

multiple surface features simultaneously can be created, something a simple absorption-type filter could never do. There are a number of planetary contrast-enhancement

filters available commercially, most of which are designed specifically for improving views of Mars.

In my experience these filters work, some better than others. Just like the use of colour filters, the improvement is very subjective. Of the filters I've tried, none stand out as being all-round better than a simple colour filter, but it may be worth it for your local astronomy club to buy one to try out as a group. I also have a general caution regarding the transmissivity of these filters: some cut a very large percentage of the incoming light, making them unsuitable for smaller-aperture telescopes.

Special Neodymium Filters

The next Special filter category, Neodymium, is kind of a sub-category of Planetary filters, except that the Neodymium filter has been adapted to a wider range of uses. The concept of using Neodymium-infused glass in an astronomical filter is somewhat serendipitous. The resulting glass media has multiple pass

ENCOUNTER

ENERGY

Sky-Watcher Quantum ED-APO Refractors

Energize your optical performance with Quantum top of the line ED-APO refractors. Quantum utilizes the most modern optical glasses and fabricating techniques to deliver the ultimate in high-fidelity astronomical imaging.

- AP0 Quality | F/7.0 Focal Ratio (Quantum 120 and Quantum 150)
- Field Flatteners (Quantum 120 and Quantum 150)
- Precision Linear Bearing Focuser | Carbon Fiber Optical Tube
- Retractable Carbon Fiber Lens Shade | Four Internal Baffles (Quantum 120)
- Aluminum Case | Full Accessory Assortment

Learn more about Quantum ED-APO Refractors by scanning the QR code with your smart phone or visit www.celestron.com/skywatcher

Sky-Watcher u.s.a.

Model Shown: Quantum 120 Refractor on CGEM Mount (sold separately)
Also available Quantum 150 and Quantum 100 Refractors

WWW.CELESTRON.COM/SKYWATCHER

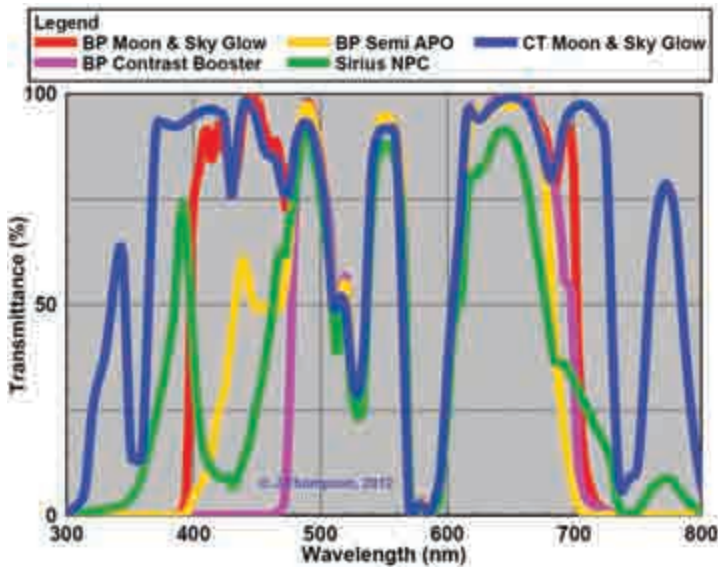

Image 3 – Spectral Response of Neodymium Filters. By infusing the filter glass media with the rare earth element neodymium, a unique and useful family of filters was created.

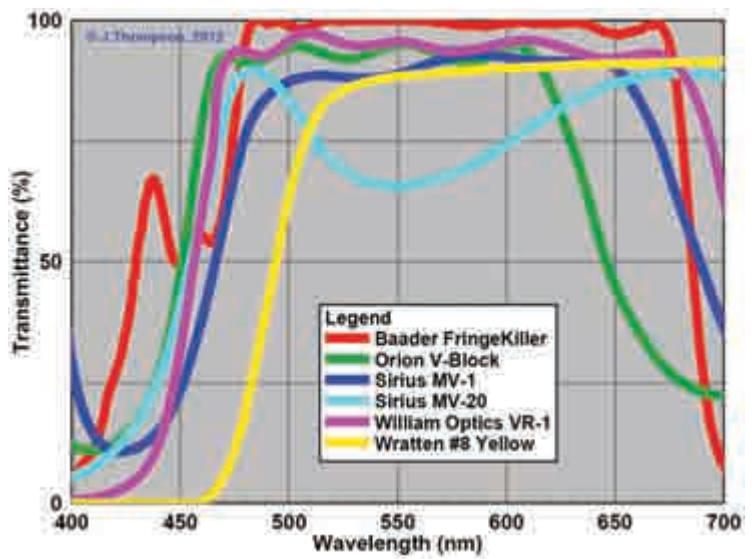

Image 4 – Spectral Response of Correction Filters. This group of filters is meant for removing the violet-blue end of the spectrum, greatly reducing the appearance of chromatic aberration in achromatic refractors.

bands in the visible spectrum, and by some strange happenstance the end result is a surprising increase in contrast. These filters are available from a number of manufacturers, and they provide good contrast improvement with high overall transmittance. I personally use a Baader Moon & Sky Glow filter whenever I view planets or the Moon.

There are a number of variations on the basic Neodymium-infused glass filter that tailor the filter for different applications. Some have interference coatings to provide UV/IR blocking, making them good for imaging. Some have additional blocking in the violet-blue end of the spectrum to improve the performance of achromatic refractors. All-in-all, they are a curious family of filters that are worth having a closer look at. Note however that even though some manufacturers say that these filters provide light-pollution reduction, the amount by which they do so is, in my estimation, negligible.

Special Correction Filters

The next category of special filters is that meant for Correction, or more specifically the correction of chromatic aberration. Different wavelengths of light bend or “refract” by different amounts in a glass

medium such as a lens. When designing a glass lens for a telescope or camera, this fact results in all the colours of light not coming to a point when focused, leaving the resulting image blurred by a violet-blue and

sometimes red fringe. For centuries, lens designer struggled to correct this problem, culminating in the multi-element exotic-glass apochromatic refractor. Apo refractors, however, are still expensive to

TELESCOPES & ACCESSORIES

Flexible RC Dew Shields
For Popular RC Astrographs

Aluminum Dew Shields
New Colony HD & Mainline ACF

Flexi-Heat Dew Shields
The Heat is On

Quality, Innovative Design at its Best

We offer dependable products to protect and enhance your valuable equipment. All Astrozap products have innovative design, high quality and represent the best values in the industry. We offer Telescopes, Artificial Stars, Dew Controllers, Dew Heaters, Dew Shields, Dust Covers, Eyepiece Trays, Focus Caps, Light Shields, Light Shields, PST Caddies, Solar Filters and more.

Astrozap
Innovative products for the modern astronomer

Babinet Focusing Screens
Sharp Precise Focus

WWW.ASTROZAP.COM ■ 216.334.1622

ASTRONOMICAL FILTERS PART 4

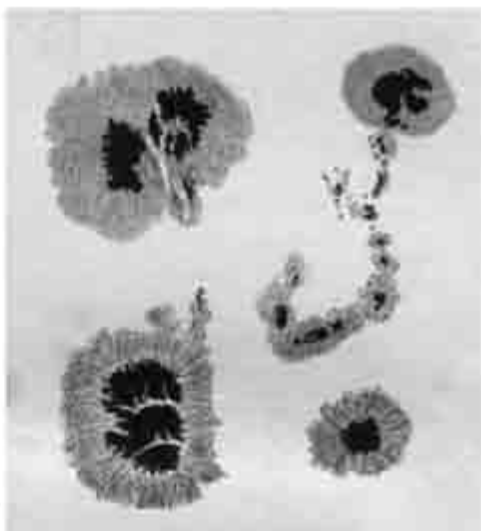
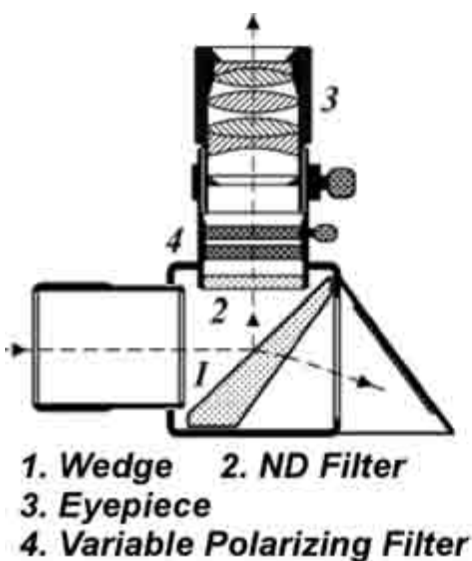

Image 5 – The Herschel Wedge. John Herschel first proposed the idea of using a wedge to split off a safe amount of sunlight for observation (left). His resulting observation sketches are as impressive today as they were 150 years ago (right).

manufacture, putting these high-performance telescopes out of the reach of many amateur astronomers.

The more affordable runner up in performance is the achromatic refractor,

which, although far better than a simple spherical lens, still has some chromatic aberration. When viewing bright objects like the Moon or planets, this aberration is often visible enough to hamper viewing.

The solution most commonly used is to add a filter that removes the unfocused violet-blue end of the spectrum. These filters commonly go by the name of “fringe killer” or “minus violet.”

You will find that these filters are more effective when used during imaging since camera detectors are more sensitive at the UV end of the spectrum than our eye. But, there is benefit to be gained using these filters visually; I have personally used the Baader Fringe Killer on my 80-mm achromatic refractor, and I can confirm that the filter does what its name suggests. If you are looking for a cheaper solution to chromatic aberration, try using a yellow Wratten #8 filter; it should help.

When using a Correction filter, you should be prepared for the fact that your view will have a yellow colour cast. The minus-violet filters offered by Lumicon and 1000 Oaks are said to have the least amount of colour cast, but they may also have correspondingly less impact on chromatic aberration. The Baader Contrast

Astronomik

Professional filters for Astronomy

Why to choose Astronomik:

Optimized transmission curves, parfocal, perfect substrate, 100% scratch resistant, not moisture sensitive, transmission of ~99%, 10 year warranty
NEW: HALO-FREE Filters

- Filters for visual observation:
UHC, OIII, H β , CLS
- Filters for photographic observation:
LRGB color filters
emission line filters H-alpha, H-beta, SII, OIII, CLS
- Filters for high-res lunar and planetary work:
ProPlanet 742 and ProPlanet 807
- A full line of accessories to use the filters.



Clip-Filter System
for Canon EOS DSLR cameras

Have a look at: www.astronomik.com

Booster and Semi-APO try to compensate for the colour cast by cutting out some of the yellow part of the spectrum. The resulting image is more pleasing, but still has a brownish tinge. Depending on your specific telescope, the increase in sharpness and contrast may be worth the false colour.

Special Solar Filters

The last Special filter category is the one which I have the least experience with: Solar. That is unfortunate since solar filters are among the most expensive filters you can buy for astronomical use. Solar viewing depends on two key parameters, safety and contrast, with safety being by far the most important. Astronomers have been looking for ways to safely observe the Sun longer than they've been looking at the stars and planets. As a result, there are a number of different options available for use today.

The main problem is that the Sun emits a large amount of energy, not just in the visible spectrum, but in the UV and IR bands as well. In fact, only 45 percent of the solar radiation reaching our eyes is in the visible band. The radiation that we can't see with our eyes is what does the damage, especially if we try to observe the sun through binoculars or a telescope. Imagine putting that magnifying glass you used to fry ants with as a kid in front of your face and staring right into the bright spot. Ouch! Whatever solar observation method you chose to use, it must eliminate the majority of this damaging radiation.

The simplest and probably the oldest method of viewing the sun is the pinhole camera. By putting a small hole in a piece of cardboard, you can project an image of the sun onto a screen and safely view it. This works surprisingly well (and is a good science project for your kids), however, it can be hard to see the projected image out in broad daylight. This concept can be taken a step further by using a normal refracting telescope with eyepiece to focus even more light onto a projection screen. The resulting image is brighter and has more contrast, however, it will result in a

heating up of your telescope and eyepiece. It is not recommended for larger aperture refractors and not at all for reflectors.

The Herschel Wedge

It was John Herschel (1792-1871), the only son of famous astronomer William Herschel, who first proposed the idea of using a wedge-shaped piece of un-silvered glass to split off a small portion of the incoming sunlight from his telescope for safe viewing. The wedge prism splits off less than 5 percent of the incoming sunlight, dumping the other 95 percent out the back of the prism. The reflected 5 percent is then passed through a neutral density (ND) filter to further reduce the light intensity to a safe level.

This system, now called the "Herschel wedge," was further improved by Ignazio Porro (1801-1875) by placing the glass wedge at an angle to polarize the reflected light, thus allowing a rotatable line-polarizer filter to be added to give adjustability

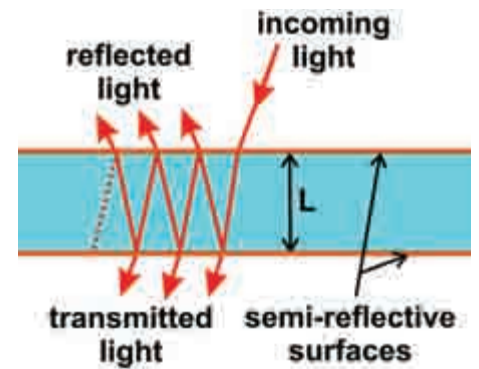

Image 6 – The Etalon, simply two parallel semi-reflective surfaces. Wave interference of the internal reflections allows only a particular wavelength to pass through. The distance between surfaces adjusts the pass band's centre wavelength, the reflectivity of the surfaces adjusts the pass band's width.

to the brightness. Herschel wedges are still available today, and many users are convinced that they give the best possible white-light views of the Sun. Herschel wedges are truly "white-light," allowing for the use of additional band-pass filters in



Optec

Pyxis LE
Camera Field Rotator



- Low profile - 0.67"
- Fits any 2" focuser
- T-thread camera adapter
- Simple to use control program
- ASCOM-Compliant

• See Website For Details •

www.optecinc.com • 888-488-0381 • sales@optecinc.com



Image 7 – Solar Scopes. Telescopes custom designed for narrowband H α observing are available in a number of apertures

order to focus observation on particular parts of the visible spectrum.

The main drawback of Herschel wedges is that all the sunlight is getting focused inside your telescope, causing potential heating problems. They are therefore most suitable for smaller-aperture refractors, and definitely not suitable for any type

of reflector be it Newtonian or SCT.

Solar Filters for Reflectors and Larger Refractors

This leaves the question: What can we reflector owners use? Luckily, filter-coating technology has come to the rescue of owners of reflectors and large refractors. De-

pending on how much money you are willing to invest, you can choose to go the way of white-light observing (affordable) or narrowband observing (expensive). Both systems use an Energy Rejection Filter (ERF) to remove 99 percent-plus of the incoming sunlight.

In white-light systems the ERF takes the form of a Mylar-type film or glass filter carrying multiple layers of a metallic compound coating. The ERF is easily mounted over the sun-facing end of your telescope, and can be full aperture (span whole diameter of

your objective) or off-axis (span only a smaller diameter circle to one side). Off-axis ERFs are usually recommended for large-aperture telescopes (>6 inches) as they remove the loss of contrast due to a reflector's central obstruction, and the effective increase in focal ratio helps reduce the appearance of atmospheric distortions.

A big advantage of front mounted ERFs is that they eliminate any risk of overheating inside your telescope. White-light ERFs are affordably priced and can be purchased from manufacturers like Baader Planetarium, 1000 Oaks Optical, or Orion Telescopes. (Coincidentally, Baader also makes a very high quality Herschel wedge.)

The ERFs for narrowband solar observing are admittedly fancier than those for white-light solar observing. They tend to be designed specifically for use with a matched narrowband H α filter, and some have adjustments that allow the filter to be further "tuned" to give the best results while observing. Narrowband ERFs can cost many hundreds of dollars, so make sure you do your homework before you buy. ERFs for narrowband solar observing are available from 1000 Oaks Optical and Baader Planetarium, among other manufacturers.

Some specialized "solar scopes," such as those sold by Lunt and Coronado, place the ERF at the eyepiece end of the telescope,

Bob's Knobs
 EASY COLLIMATION FOR 5" to 16"
MEADE & CELESTRON SCT
 Meade Lightbridge
 and many others

Also No-Tools Losmandy Setup

6976 Kempton Rd.
 Centerville IN 47330
 765-855-5109 USA

www.bobsknobs.com





GARRETT OPTICAL
 PERFORMANCE SPORT OPTICS

**Garrett 100mm F/5.3
 45° Binocular Telescope**

Enjoy the light-gathering power of two 100mm refractors - one for each eye - and the flexibility to interchange 1.25" telescope eyepieces.



More Info: <http://www.AstronomyBinoculars.com>

making them suitable only for use with their narrowband H α filters.

Other than the proper ERF, you don't really require anything else for white-light solar viewing. If you wish, you can purchase extra band-pass filters to use with your ERF. Some examples include the Solar Continuum filter (540 nm) from Baader for increasing contrast of granulation and sunspots, Calcium K-Line (395 nm) for sharp-contrast views of super-granulation and flares using a camera (not for visual), or even a traditional H α band-pass filter (656 nm) meant for nebula observing. I have even used my O-III nebula filter (with Baader AstroSolar film for an ERF) and had a marked increase in contrast.

Note that some white-light ERFs have a slight colour cast, most often orange, that may restrict the use of band pass filters. Adding band-pass filters to your white-light setup increases the cost somewhat, but still nowhere near what a true narrowband system costs.

As mentioned earlier, narrowband solar observing systems use specially designed ERFs that are precisely matched to the narrowband H α pass filter. Calling the H α filter narrowband is an understatement: a narrowband H α filter for deep-sky imaging has a pass band around 3 to 7 nm wide,

while for solar observing they are more like 0.02 to 0.09 nm wide! Up to this point I have been calling this later group "H α filters," when strictly speaking they are not filters, they are "etalons." Both function using the same principle of the interference of light, but implement it differently.

As in an interference filter, light enters an etalon, passing from air into the optical media (i.e., glass), and partly reflects, partly refracts at the boundaries between air and glass. Some etalons use an air space between the semi-reflective coatings instead of a clear glass media. By carefully selecting the distance between the semi-reflective layers and their reflectivity, the etalon can be made to selectively pass a particular wavelength of light.

The passed wavelength can be further adjusted by either varying the distance between the layers or rotating the etalon relative to the incoming light. This is an important characteristic of etalons as it allows the observer to tune their etalon to account for wavelength variations in the H α emissions coming from the Sun. You maybe haven't thought about it, but the relative speed difference from one side of the Sun to the other due to its rotation is enormous, on the order 14,000 km/h (9000 mph)! This speed difference, plus that

caused by Earth's rotational velocity and orbital velocity, results in a wavelength shift up or down of the H α emission line, a characteristic of light first predicted by Christian Doppler in 1842 and later confirmed in the emission lines of stars by Hippolyte Fizeau in 1848.

As one can imagine, the precisely applied reflective coatings and ability to very finely adjust the spacing/orientation of the etalon makes these devices very expensive. ERF-plus-etalon packages for small aperture telescopes range in price from \$800 to several thousand. The cost of buying these packages separately has made solar scopes such as those from Lunt and Coronado, with the ERF and etalon fully integrated into the scope, another possible alternative worth considering. There is no doubt that these narrowband H α systems provide by far the best views of the Sun. Whether or not the view justifies the cost is a decision you will have to make for yourself.

For questions or comments, please contact me at: karmalimbo@yahoo.ca 

Eclipse Tour with ATT contributor Dr. James Dire



<http://www.innovationsintravel.com/> (410) 268-2883

HUBBLE OPTICS

16" f/4.5 Premium Ultra Light Dob
Priced At Only \$2295!



Light, Strong, Compact And Extremely Portable



Exclusive Optical Technology With Lightweight Sandwich Mirror



www.hubbleoptics.com